

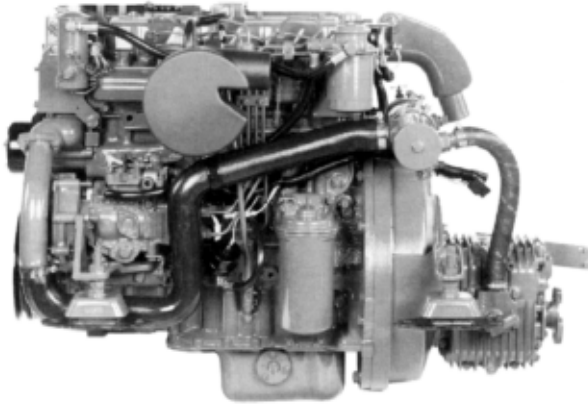

## Extra low-end power at 2600 rpm...



64A Diesel Engine

### Smooth and Quiet

The 64A Four offers 4-cylinder, 4-cycle smoothness. A tuned air intake silencer and 4-point vibration mounts diminish sound and vibration for a smooth and quiet ride.

### Powerful and Reliable

The naturally aspirated 2.98 liter design of the 64A Four provides instant power as well as simplicity and reliability. The 64A Four is rated at a low 2600-rpm for longer engine life and delivers dependable power.

### Easy Operation and Maintenance

In order to minimize engine maintenance, a fresh water cooling system and self-bleeding fuel system are designed into the 64A Four. Some benefits are a standard front-mounted, raw water pump as well as a positive flow, hot water heater connection in the thermostat bypass circuit.

### Many Optional Accessories

Many optional accessories are available including large single and dual output battery charging alternators and refrigeration compressor mounts. Factory engineered and factory installed, an owner or builder benefits from these complete and properly designed systems.

### The Name You Can Trust

The presence of Westerbeke in over 65 countries around the world provides customers with easy access to parts, service and technical support worldwide. Established in 1937, Westerbeke is committed to providing its customers with quality products and unequalled after sales support.

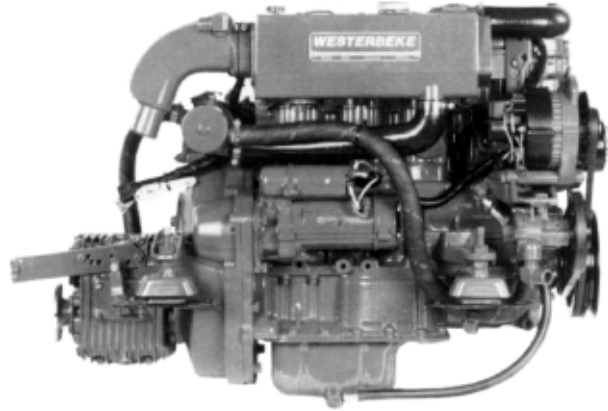

64A Diesel Engine

### Standard Features

- Engine pre-wired to plug-in connector
- Circuit breaker protected electrical system
- Self-bleeding fuel system
- Belt-driven, raw water pump
- Fresh water cooled engine
- Fresh water lube oil cooler
- Transmission oil cooler
- 12 volt, 50 amp alternator
- Domestic hot water connection
- Coolant recovery tank
- Throttle, stop, and shift control brackets
- Low oil pressure and high water temperature alarms
- Marine transmission with 2:1 reduction
- Glow plug cold starting aid
- Engine matched four-point, fail-safe, adjustable mounts
- Lube oil drain hose
- Tuned air intake silencer
- Operators' manual and parts list
- "CE" mark
- Large list of factory engineered options



*Optional Admiral Panel*

### Admiral Panel Dimensions

Length	9.75" (247.7 mm)
Depth	4.0" (101.6 mm)
Height	6.0" (152.4 mm)

**Performance Data**

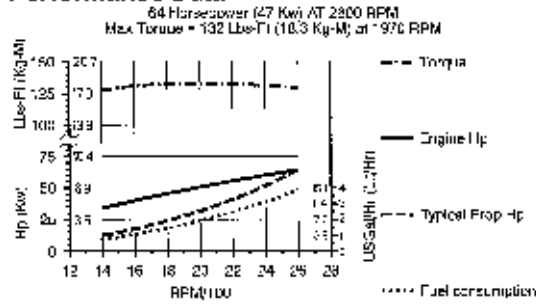

**Specification**

Number of cylinders	4 Cylinder vertical in-line
Cycles	4 Cycle
Displacement	182 cu. in. (2.977 liter)
Bore and stroke	3.74" x 4.13" (95 mm x 105 mm)
Compression ratio	21:1
Maximum angle of installation	Not to exceed 14°
Maximum angle of operation	Not to exceed 25°
Crankshaft, direction of rotation	Counterclockwise as viewed from flywheel end
Propeller shaft, direction of rotation	Right hand – std. trans.
Dry weight	678 lbs (307.5 kilos)
Combustion system	Swirl type
Aspiration	Naturally aspirated
Lubrication system	Forced lubrication by gear pump
Cooling system	13 quarts (12.3 liters)
Starting aid	12 volt sheathed type glow plug
Engine stop	Electric
Fuel injection pump	Bosch type
Governor	Centrifugal type
Injectors	Throttle type
Fuel filter	Full flow, spin-on element
Lube oil filter	Full flow, spin-on element
Lubricant capacity	6.5 quarts (6.2 liters)
Lube oil cooler	Fresh water cooled
Fuel transfer pump	Electrical
Fuel supply and return piping	1/4" ID (6.35 mm) minimum 3/8" ID (9.53 mm) maximum
Starting motor	12 volt, solenoid, actuated shift
Battery charging alternator	50 ampere (12 volts)
Cold cranking amps	250-300 amps
Electrical system	12 volts DC, negative ground

**Construction—Engine Components**

Cylinder head	Cast Iron
Cylinder block	Cast Iron
Crankshaft	Forged crankshaft, five main bearings
Valves	Overhead valves, rotating type
Fuel System	Self bleeding
Intake system	Tuned intake silencer for maximum noise reduction
Cooling system	Fresh water-cooled with oversized tube and shell type heat exchanger
Exhaust manifold	Cast aluminum, fresh water-cooled with built-in expansion tank

**Standard Equipment**

Standard gear ratio	2:1
Mounting centers	20.0" and 22.5"
Flexible mounts	Oversized adjustable fail-safe rubber type
Domestic hot water connection	
Coolant recovery tank	
Battery charging alternator	50 amp, 12 volt
Starting aide	
Control brackets	Throttle and shift
Prewired Engine	
Belt-driven sea water pump	
Lube oil cooler in fresh water system	
Lube oil drain hose	
Transmission oil cooler	
Oil fill	Top
Circuit breaker protected electrical system	
Operator's Manual and Parts List	

**Optional Equipment**

- Captain panel with alarm (tachometer with lights)
- Admiral panel with alarms (tachometer with gauges)
- Dual station senders
- Other gear ratios Consult local Distributor
- Hydraulic transmissions Consult local Distributor
- Remote expansion tank
- Provisions for refrigeration compressor
- Muffler and fittings
- "A" and "B" on board spare parts kits
- Alternator, 90 amp single output; 135, 160, 190 dual output
- Anti-siphon valve for overboard cooling discharge water
- Technical Manual
- Exhaust connection (water injected 70° elbow)
- Propeller shaft couplings (rigid/flexible)—available standard sizes

**Dimensions**

Inches (millimeters)

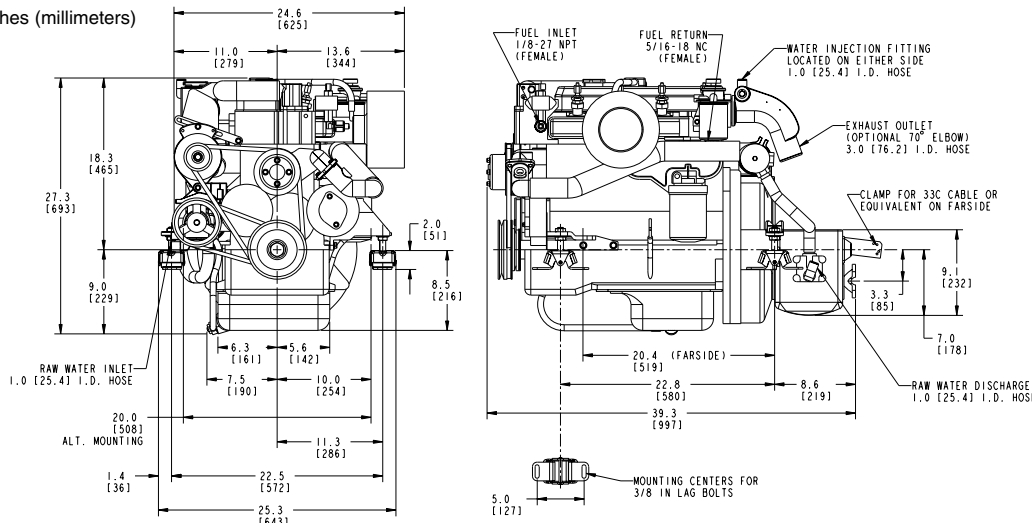

Authorized Dealer