

# Instruction for Single Line Reef

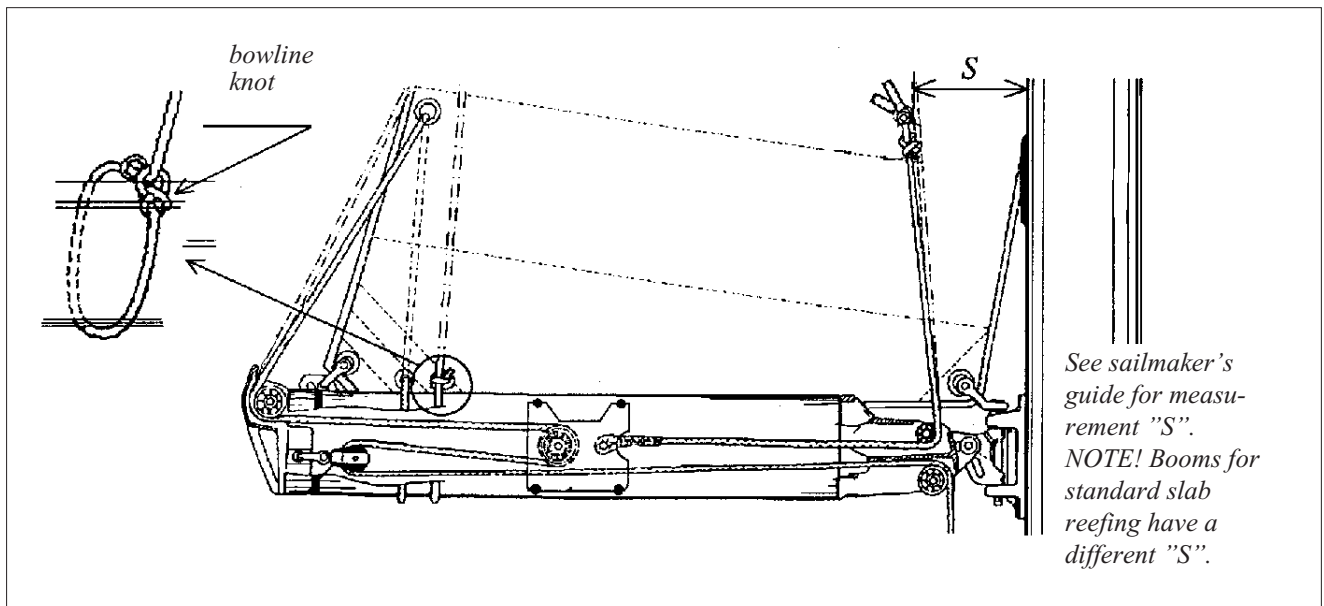

## 1. Reefing

- 1.1 Ease the kicking strap and mainsheet. Ease the main halyard by slightly more than the height of the reef. The halyard can be suitably marked to facilitate this.
- 1.2 Haul in on #1 reef line (white/blue reef line) so that both the luff and the leech cringles are pulled down to the boom.
- 1.3 Tension the main halyard, then the mainsheet and kicking strap.
- 1.4 Take up the slack in the reef line #2 (white/red reef line).
- 1.5 Reef #2 is taken in according to 1.1–1.3 above.

## 2. Removing a reef

- 2.1 If only reef #1 has been taken in loosen the second reef line (see 1.4).
- 2.2 Ease the kicking strap and mainsheet.
- 2.3 Ease the reef line.
- 2.4 Tension the main halyard, then the mainsheet and kicking strap.



### Caution!

The space between the boom sides and internal running blocks is limited. Check that new fittings, pop rivets or screws do not obstruct the movement of the blocks.

 **SELDÉN**

[www.seldenmast.com](http://www.seldenmast.com)